



Universal Seal for standard bag



Use :

Manual clamping, removal with tool

Material :

Polypropylene

Rod diameter :

7.5 mm

Rod nature :

Flat

Typology :

With progressive tightening

Rod length :

Overall = 453 mm ; Usable without spikes = 350 mm
Usable with spikes = 330 mm

Head dimension :

Plate = 60 x 23 mm

Options :

- with or without pins
- with or without self-adhesive labels on the back

ADDITIONAL INFORMATION :

Conditions of use :

From - 30°C to + 40°C

Durability :

50 kg (500N)

Colors :

Yellow, red, blue, green, white, orange

Insert :

Metalic

Engraving :

Label marking

Type of marking :

Name, numbering, bar code

Packaging :

Pin of 10 pieces – Box of 1 000 pieces

Field of application :

Bank and cash transport, Food industry, Chemical and pharmaceutical Industry, Medical, Recycling, Security and defense, Transport and logistics

PLAN :

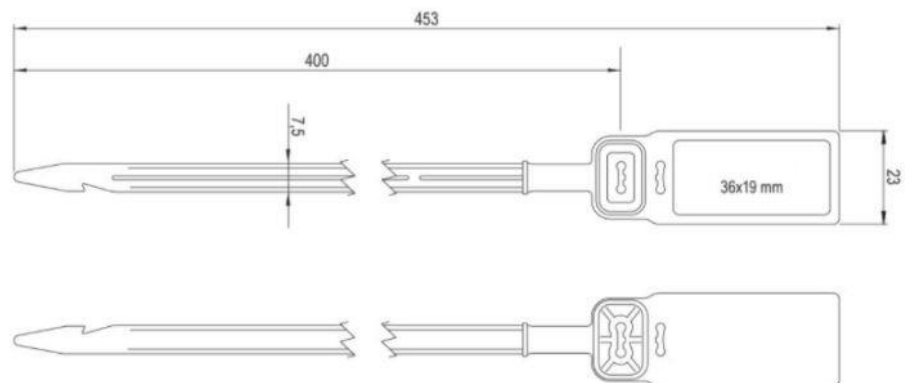

Universal Bag seal with Tear-off

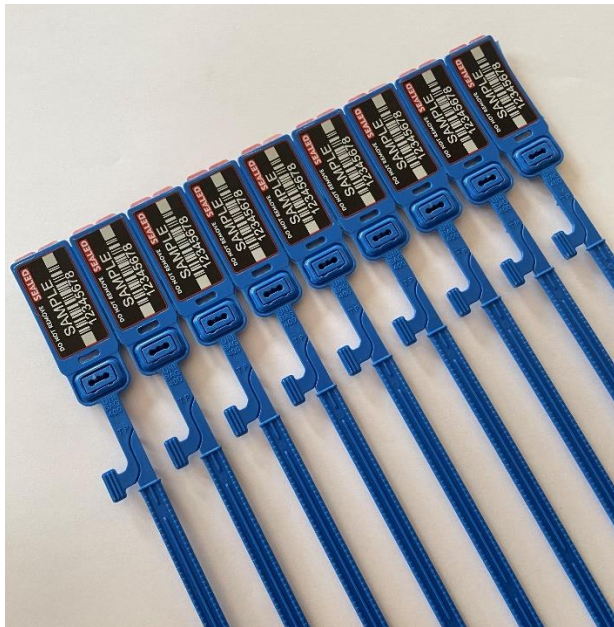

Use :
Manual clamping, removal without tool

Material :
Polypropylene

Rod diameter :
7.5 mm

Rod nature :
Flat

Typology :
With progressive tightening

Rod length :
Overall = 453 mm ; Usable = 330 mm

Head dimension :
Plate = 60 x 23 mm

Option :
- With or without self-adhesive labels on the back

ADDITIONAL INFORMATIONS :

Conditions of use :
From - 30°C to + 40°C

Durability :
50 kg (500N)

Colors :
Yellow, red, blue, green, white, orange

Insert :
Metalic

Engraving :
Label marking

Type of marking :
Name, numbering, bar code

Packaging :
Pin of 10 pieces – Box of 1 000 pieces

Field of application :
Bank and cash transport, Food industry, Chemical and pharmaceutical Industry, Medical, Recycling, Security and defense, Transport and logistics

PLAN :

